

—WARNING—

Read all instructions before beginning installation or use of this gate opener.

This operator exerts a high level of force.

Excercise caution at all times and stay clear of the system during operation.

Estate SWING

ESTATESWING.COM

E-S 300 / 302 Classic Series

INSTRUCTION MANUAL

Estate Swing Summary of Functions

The Estate Swing is only to be used for vehicular swing gates in a Class I setting.

Class I: A vehicular gate opener (or system) intended for use in a home of one-to-four single family dwelling, or a garage or parking area associated therewith.

The Estate Swing automated system was designed and built for controlling vehicle access. Do not use for any other purpose.

The external automation with an electro-mechanical non-reversing linear arm automates residential swing-leaf gates with leaves of up to 12' in length. It consists of an irreversible electro-mechanical operator with built in opening and closing limits and utilizes a worm screw system. The irreversible system ensures the gate is mechanical locked when the motor is not operating. A lock still needs to be installed if security or high winds are a concern. A manual release makes it possible to move the gate in the event of a power-cut or fault.

For Your Assistance

Keep this manual safely stored after installation

Serial Number _____

Date of Purchase _____

Place of Purchase _____

Have this information on hand while handling all service and warranty issues.

Table of Contents

The table of contents are listed to assist you locating a desired section. We do however strongly suggest studying every page of the instruction manual before attempting installation.

Section 1: Review of Specifications, Warnings, and Tools

Specifications of the Estate Swing and Components	1.1
Parts List	1.2
System Overview & Preliminary Checks	1.3
Tools Needed for Installation	1.4

Section 2: Installation

Manual Operation, Restoring Automation	2.1
IMPORTANT: Determining Setback—Pull to Open	2.2
Installation of Operator—Pull to Open	2.4-5
IMPORTANT: Determining Setback—Push to Open	2.6
Installation of Operator—Push to Open	2.7-8

Section 3: Wiring, Jumpers and Receiver

Removing Terminal Strips for Wiring	3.1
Wiring of Operator Arm(s) (Pull & Push to Open)	3.2
Installing Receiver and Setting Transmitters	3.3
Temporary Safety Jumpers & Dip Switch Settings	3.4
Power	3.5

Section 4: Programming the Operator

Adjust limit switches and determine run time	4.1-2
Operating Parameters Settings	4.3

Section 5: Troubleshooting & Accessories

Troubleshooting	5.1-3
Control Board Overview	5.4-7
Accessories	5.8

Specifications

MODEL	Estate Swing E-S300/302
Power Supply	24V AC, 50VA to 120VA
Backup Battery Voltage	24V DC
Current (A)	3
Travel (in.)	13
Cycles per hour	50% Duty Cycle / Aprox. 35
Operating Ambient Temp	-20 to 130 F
Protection class	IP44
Gate leaf max length (ft.)	Up to 12
Gate leaf max weight (lbs.)	Up to 600
Operator Type	Screw Drive
Operator Weight	14 lbs

Gate Weight/Length Ratio	6'	8'	10'	12'
100lbs	X	X	X	X
200lbs	X	X	X	X
300lbs	X	X	X	X
400lbs	X	X	X	
500lbs	X	X		
600lbs	X			

The above chart represents the maximum weight and length combinations that this gate opener can handle. The lengths and weights are either for a single gate or for a single leaf of a dual gate.

Estate Swing Parts List



Master or Single Operator

- A. Control Box with Control Board and Receiver
- B. Operator Arm with 7' of Wire
- C. Key
- D. Transmitter
- E. Transformer
- F. Gate Mounting Bracket
- G. Post Mounting Brackets
- H. Connector Pins and C Rings
- I. Mounting Hardware
 - 1 - 3/8"x1 3/8" Hex bolts, washer, nut
 - 1 - 5/16"x 1 3/8" Hex bolt, washer, nut
 - 2 - 3/8"x 2" Carriage bolt, washers, nut
 - 1 - 1/4" x 2" Hex bolt, washers, nut

Slave Operator (if applicable)

- A. N/A
 - B. Operator Arm with 7' of Wire
 - C. Key
 - D. N/A
 - E. N/A
 - F. Gate Mounting Bracket
 - G. Post Mounting Brackets
 - H. Connector Pins and C Rings
 - I. Mounting Hardware
 - 1 - 3/8"x1 3/8" Hex bolts, washer, nut
 - 1 - 5/16"x 1 3/8" Hex bolt, washer, nut
 - 2 - 3/8"x 2" Carriage bolt, washers, nut
 - 1 - 1/4" x 2" Hex bolt, washers, nut
- Not Shown: Additional Wire

Standard System Overview and Safety Zones

The system display to the below is a recommended standard system. Other approved accessories can be installed. Photo sensors and a flashing light indicating gate movement is recommended for safety purposes.

1,2 Estate Swing Operator • 3 Photocells (not included) • 4 Control board • 5 N/A
6 Push button opening device (not included) • 7 Receiver extension (not included) • 8
24Vdc flashing lamp (not included) • 9 Positive stop (not included) • 10 AC transformer

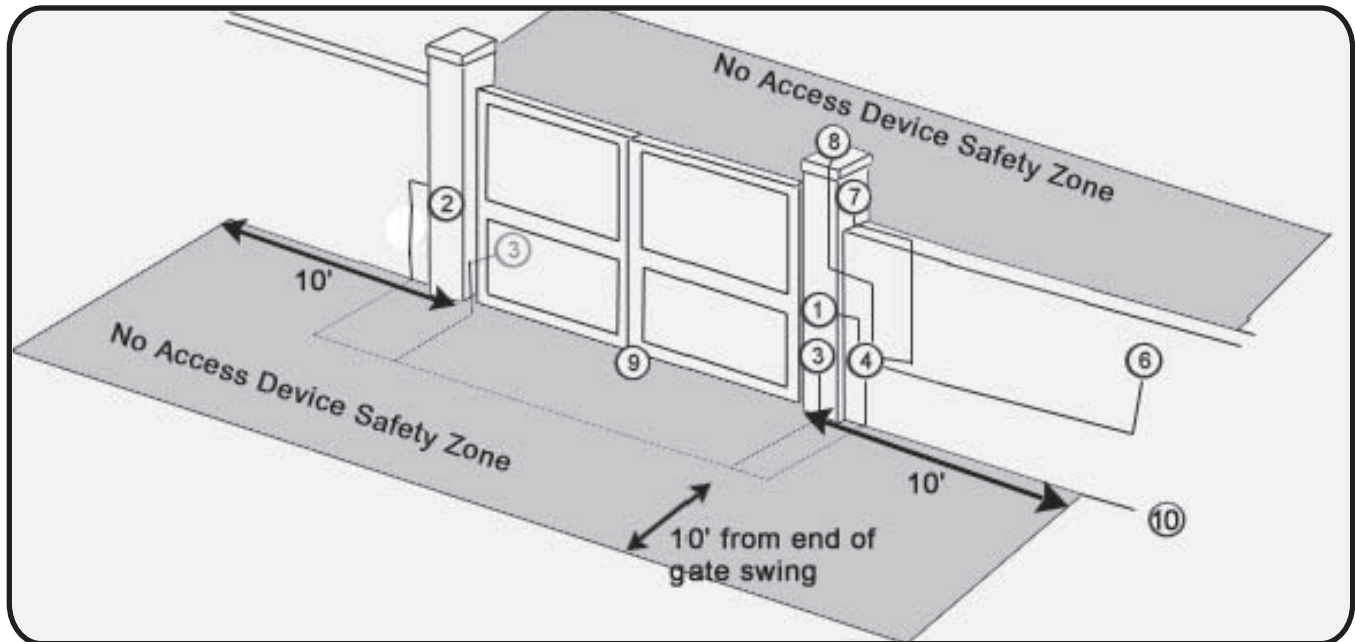

Notes: 1) When laying electrical cables, use appropriate rigid and/or flexible tube
2) Do not run any wires in the same conduit as 110 AC power that may be in the area. This will cause danger of electrocution.

IMPORTANT: Preliminary Checks

To ensure safety and an efficiently operating automated system, make sure the following conditions are observed.

- The gate and post must be suitable for being automated. Check that the structure is sufficiently strong and rigid, and its dimensions and weights conform to those indicated on page 1.
- Make sure the leaves move smoothly without any irregular friction during entire travel.
- Make sure the hinges are in good condition. Ball bearing hinges are ideal for gates weighing over 200 lbs. or over 10' in length.
- Make sure the gate is plumb and level.
- The fence post must be secured in the ground with concrete. This will prevent alteration of alignments and leveling during installation and during cycles.

Tools Needed for Installation



- Power Drill
- Crescent Wrench
- Flat Head Screwdriver
- Hacksaw
- Phillips Head Screwdriver
- Screwdriver

- C-Ring Pliers
- Tape Measure
- Level
- Wire Strippers
- C-clamps
- 3/8", 1/4", 5/16" Drill Bits

Other items may be needed prior to commencing installation. **BOLDED** items are necessary to all applications.

- Positive post, bracket or door stop. Although the Estate Swing 300 features built in limit switches it is highly recommended to have positive stops.
- **16, 14 or 12 gauge, 2 conductor stranded direct burial low voltage wire** will be required to run power to your operator. Length and gauge are determined by distance between transformer power supply and the control box.
- **4 - 3/8" Carriage Bolts** will be needed to connect the **2 "L" shaped brackets** to the post. Length will be determined by the size of your posts.
- A metal support bracket may be needed to achieve the appropriate desired setback. The metal support bracket will be bolted or welded to your post to give a larger amount of space to mount the provided mounting bracket.
- A voltage meter and digital camera may be necessary to run diagnostic checks.
- If your transformer is going to be plugged into an outdoor outlet you will need to weatherproof that outlet and transformer. **Electrical boxes or plug covers** can be obtained from a local hardware store to accommodate both the plug and transformer.
- Hardware to attach the control box to a post or fence.
- Watertight connectors for running wires into the control box.

Manual Operation



- 1) Lift lock cover cap off.
- 2) Insert and turn provided key.
- 3) The operator can now be pull or push open.
- 4) Replace lock cover to protect lock from water and debris.

To exit manual mode, repeat the above steps.

Restoring Automation

To maintain the proper performance of your emergency release - please perform the following service for your motor once per year.

1. Remove the emergency release cap
2. Spray some WD-40 or other spray lubricant into the release lock.
3. Allow the lubricant to soak in.
4. Apply a liberal dab of petroleum based jelly or wheel bearing grease to coat the release lock.
5. Put the cap securely back in place.



IMPORTANT: Determining Correct Setback

PULL TO OPEN - Standard operation. This means the gate operator is mounted on the inside of the property and pulls your gate in towards the property. If you are going to use push to open operation "X" out the next 3 pages and use the push to open section instructions.

To the right are 3 common examples of setback mountings. These are not the only options for mounting.

There are 3 factors to keep in mind when finding the setback mounting:

- 1) The measurements must be correct from the center of the hinge of the gate to the center of the hole on the mounting bracket.
- 2) There must be clearance for your opener to attach to your gate in the closed position.
- 3) The brackets do not move or pivot after mounting, if you can achieve the setback and clearance then bracket position is inconsequential.

It is best to C-Clamp brackets on and test arm movement clearance before permanently attaching them.

Variations to the ideal setback can be made, so long as the total is less than the combined measurements for the desired opening arc and the motor body is more than 2 inches away from the gate in both the open and closed position. (setback variations significantly reduces the length and weight capacity of the operator)

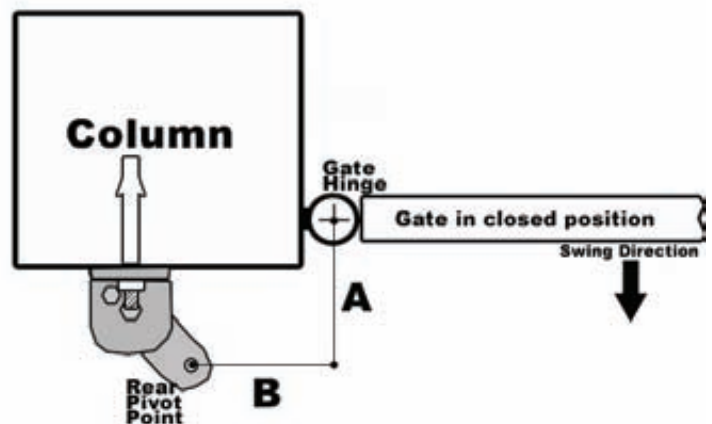
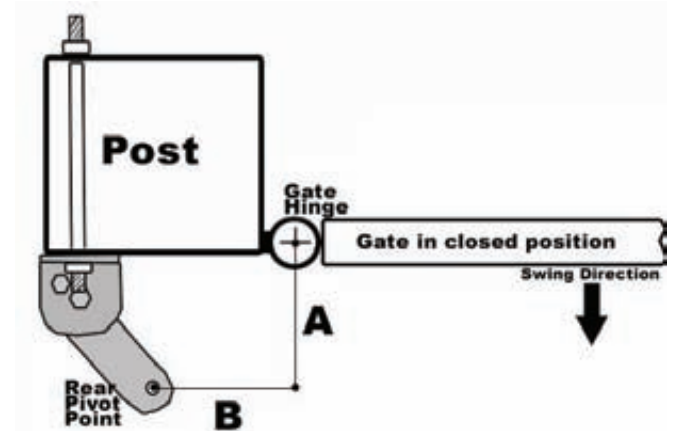
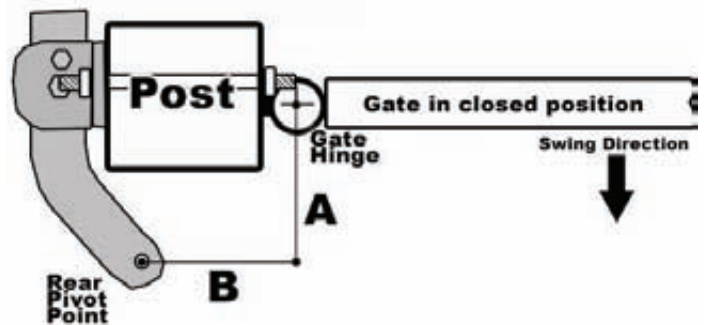

A	B	Sum	<i>a</i>
4 3/4"	5 1/4"	10	110°
5 1/4"	5 1/4"	10 1/2	100°
5 1/2"	5 1/2"	11	90°

To determine the position of the gate mounting bracket (above is for the post mounting bracket) refer to step 6 in the section "Installation of operator"

Installation of Operator—Pull-to-Open

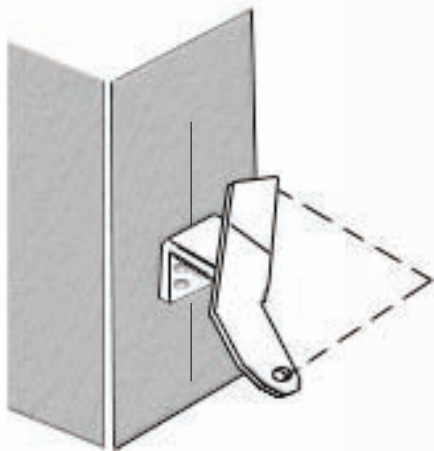

1. Find the proper set back for your operator (from previous page). Do this by holding the bottom “L” shaped bracket against the post. Marking its horizontal positioning on the post using a vertical line up from the middle of the bracket. Also mark your angled bracket for positioning on the “L” shaped bracket. The hole on the end of the angled bracket should be in the setback position.

HINT: Trace the bracket on cardboard and use the cardboard to make a template.

2. Cut off the excess length (if any) of the angled bracket using a hacksaw.

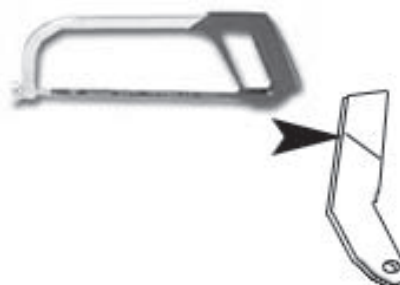

3. Position the angled bracket between the two “L” shaped brackets in the same position as when the setback was found. Clamp the 3 brackets together. Drill through the angled bracket using the pre-drilled holes in the “L” shaped brackets using a 3/8” drill bit. Drill through all three brackets using a 5/16” drill bit in a position behind the first hole.



4. Insert a 3/8” x 1” bolt in the center hole and a 5/16” bolt in the rear hole. Secure them using the provided nuts and lock washers.

BEFORE PERMANENTLY ATTACHING ANY BRACKETS, BE SURE TO TEST ARM MOTION AND CLEARANCE.

Installation of Operator—Pull-to-Open

5. Temporarily position the gate side mounting bracket. (horizontal position does not matter, vertical position on the gate is the position you are matching to the post bracket.) Position your assembled gate mounting along the previously drawn vertical line and level the angled piece with the horizontal piece of the gate mounting bracket using a level. Mark your holes, drill and attach the brackets using 4) 3/8" carriage bolts.

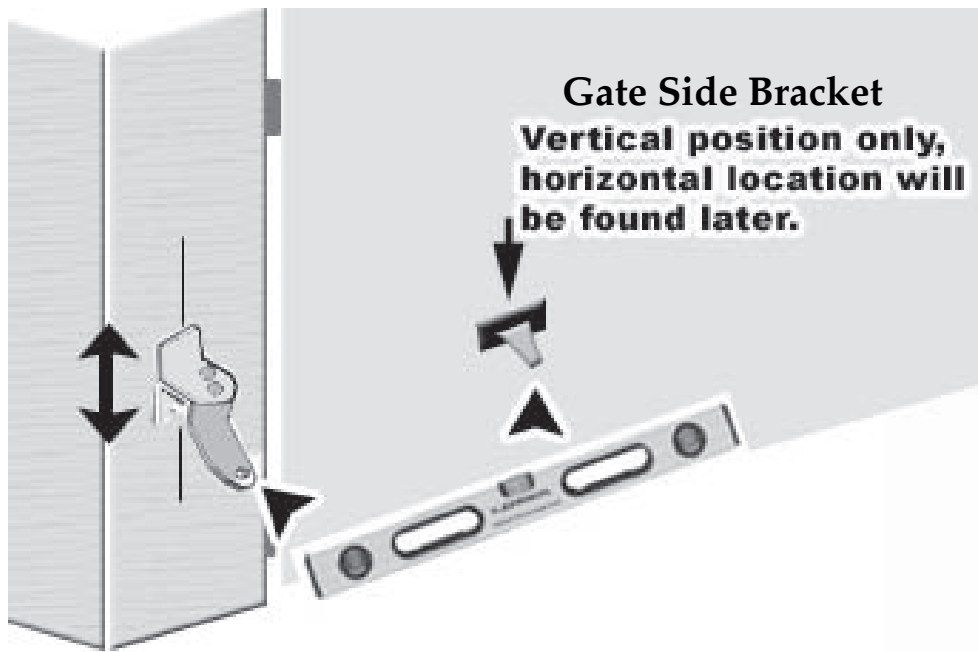

6. WITH THE GATE IN THE CLOSED POSITION measure 38" from the center hole of the "boomerang" shaped bracket to the center hole of the gate bracket – this should be the position of the gate bracket on the closed gate.

7. Attach the gate mounting bracket using carriage bolts, nuts, and washers.

IMPORTANT: Determining Correct Setback

PUSH TO OPEN - This operation is commonly used if your driveway slopes up after the gate, preventing it from swinging in. This means the gate operator is mounted on the inside of the property and pushes your gate out away from the property.

To the right are 2 common examples of setback mountings. These are not the only options for mounting.

There are 3 factors to keep in mind when finding the setback mounting:

- 1) The measurements must be correct from the center of the hinge of the gate to the center of the hole on the mounting bracket.
- 2) There must be clearance for you opener to attach to your gate in the open position.
- 3) The brackets do not move or pivot after mounting, if you can achieve the setback and clearance then bracket position is inconsequential.

It is best to C-Clamp brackets on and test arm movement clearance before permanently attaching them.

To determine the position of the gate mounting bracket (above is for the post mounting bracket) refer to step 6 in the section "Installation of operator - PTO"

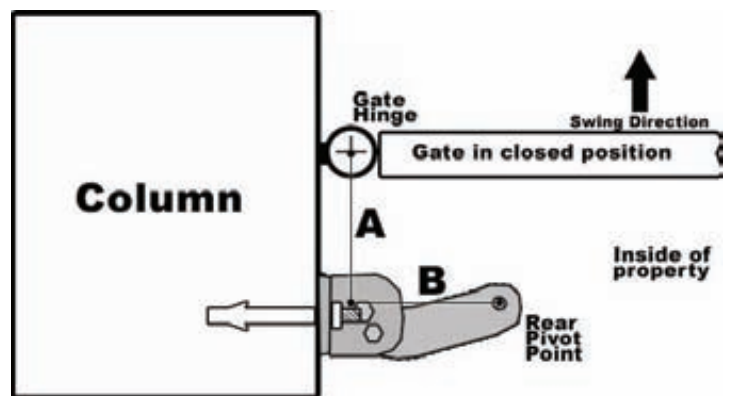
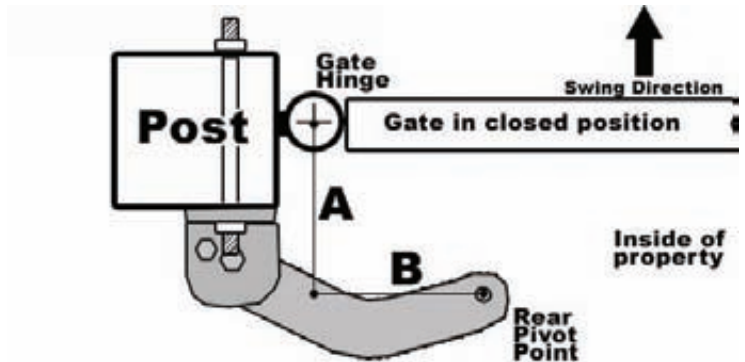

A	B	Sum	<i>a</i>
4 3/4"	5 1/4"	10	110°
5 1/4"	5 1/4"	10 1/2	100°
5 1/2"	5 1/2"	11	90°

Variations to the ideal setback can be made, so long as the total is less than the combined measurements for the desired opening arc and the motor body is more than 2 inches away from the gate in both the open and closed position. (setback variations significantly reduces the length and weight capacity of the operator)

Installation of Operator—Push-to-Open

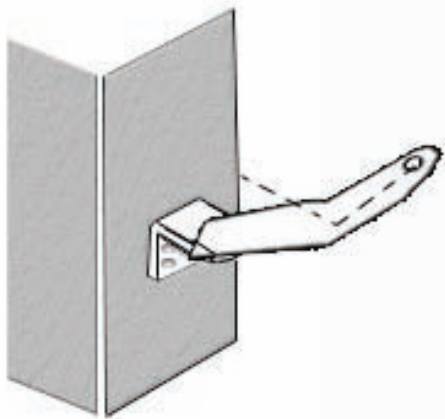

1. Find the proper set back for your operator (from previous page). Do this by holding the bottom “L” shaped bracket against the post. Marking its horizontal positioning on the post using a vertical line up from the middle of the bracket. Also mark your angled bracket for positioning on the “L” shaped bracket. The hole on the end of the angled bracket should be in the setback position.

HINT: Trace the bracket on cardboard and use the cardboard to make a template.

2. Cut off the excess length (if any) of the angled bracket using a hacksaw.

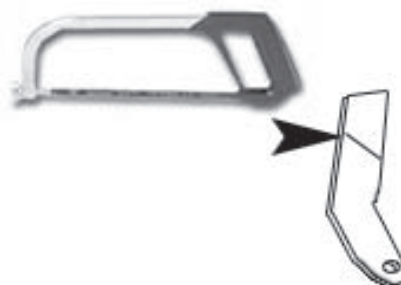

3. Position the angled bracket between the two “L” shaped brackets in the same position as when the setback was found. Clamp the 3 brackets together. Drill through the angled bracket using the pre-drilled holes in the “L” shaped brackets using a 3/8” drill bit. Drill through all three brackets using a 5/16” drill bit in a position behind the first hole.

4. Insert a 3/8” x 1” bolt in the center hole and a 5/16” bolt in the rear hole. Secure them using the provided nuts and lock washers.

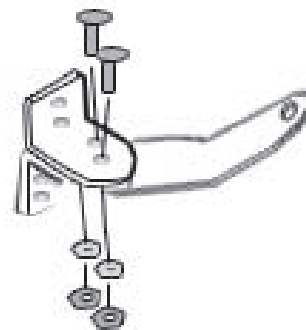

BEFORE PERMANENTLY ATTACHING ANY BRACKETS, BE SURE TO TEST ARM MOTION AND CLEARANCE.

Installation of Operator—Push-to-Open

5. Temporarily position the gate side mounting bracket. (horizontal position does not matter, vertical position on the gate is the position you are matching to the post bracket.) Position your assembled gate mounting along the previously drawn vertical line and level the angled piece with the horizontal piece of the gate mounting bracket using a level. Mark your holes, drill and attach the brackets using 4) 3/8" carriage bolts.

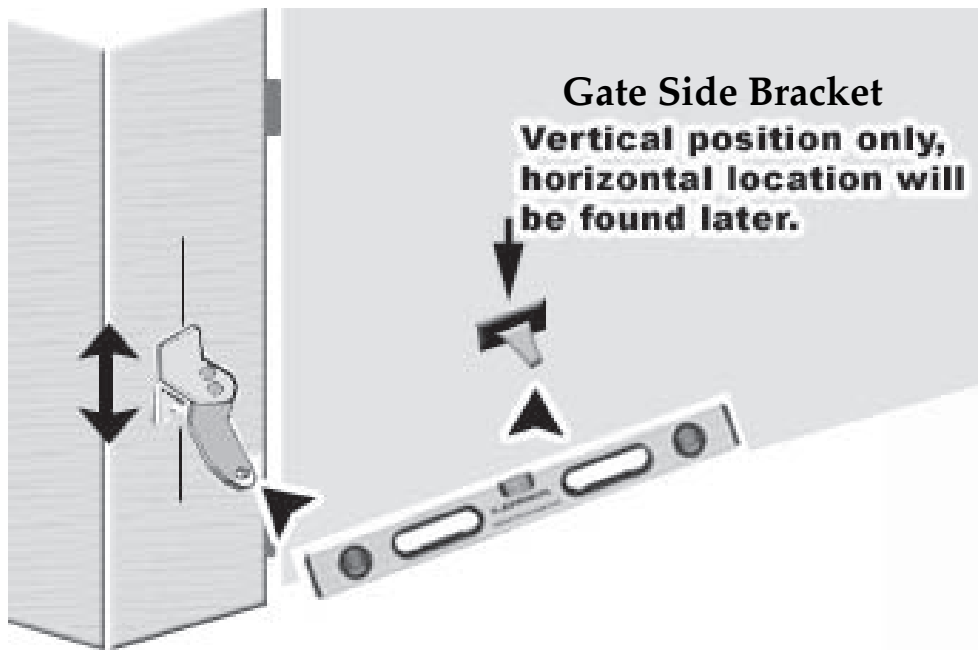

6. WITH THE GATE IN THE CLOSED POSITION measure 38" from the center hole of the "boomerang" shaped bracket to the center hole of the gate bracket – this should be the position of the gate bracket on the closed gate.

7. Attach the gate mounting bracket using carriage bolts, nuts, and washers.

For Your Convenience

The green terminal strips on the control board are easily removed for wiring. Simply pull straight out on the terminal strip to remove it from the board. It will slide right off. Slide it back on when you are finished with your wiring connections.

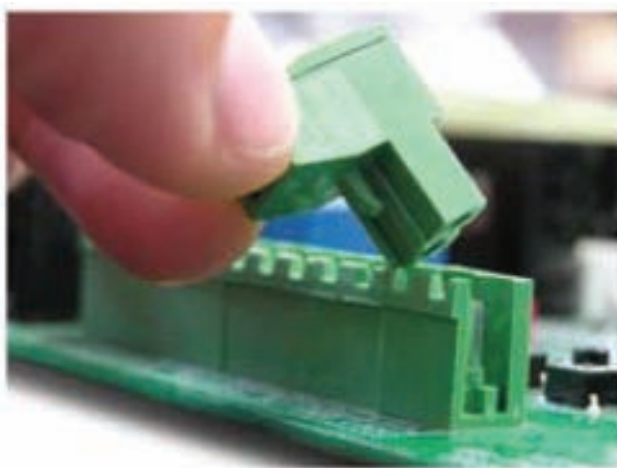

Be sure you are placing your wires in the terminal block correctly.

Take the terminal block off of the control board to insert wires. Hold with screw terminals facing upward.

Turn the screw counter-clockwise to open the terminal and clockwise to close the terminal.

The terminals come closed. Be sure not to mistake this for open and insert the wires below the terminal clamp. This will lack the conductivity to complete the circuit.

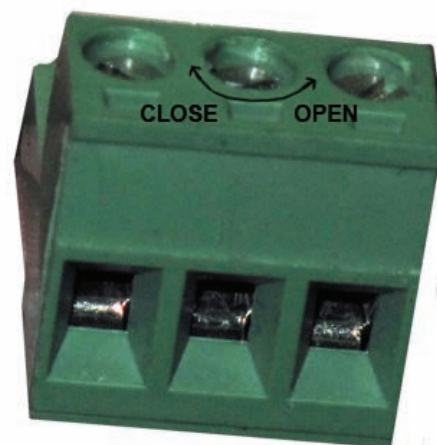

Wiring the Operator Arm(s)

For a dual gate use the provided wire to connect the secondary motor to the control board.

Feed the wires through the white wire caps at the bottom of the board. If gaps exist in the rubber wire cap after feeding the wires through, seal with silicone.

Pull to Open
(Opening in towards property)

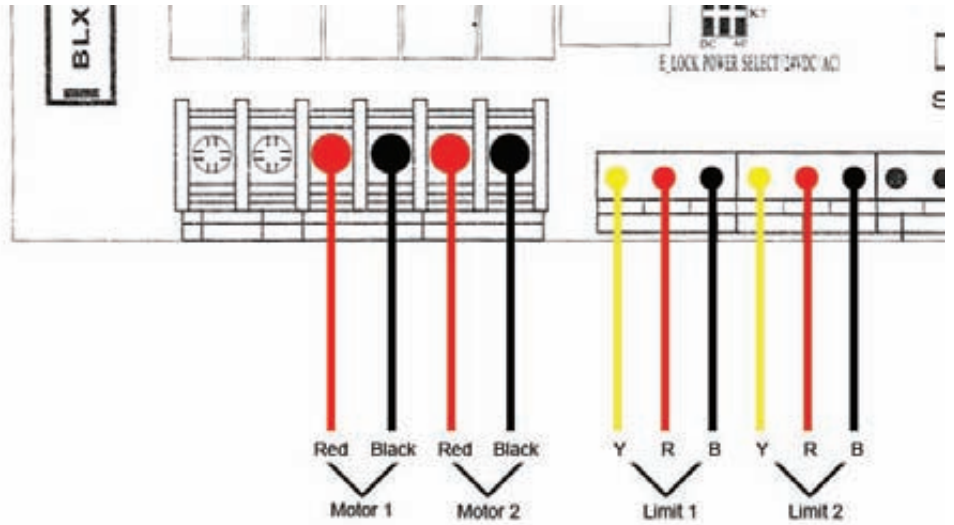

It is important to choose the correct operation type

Push to Open
(Opening out towards the street)

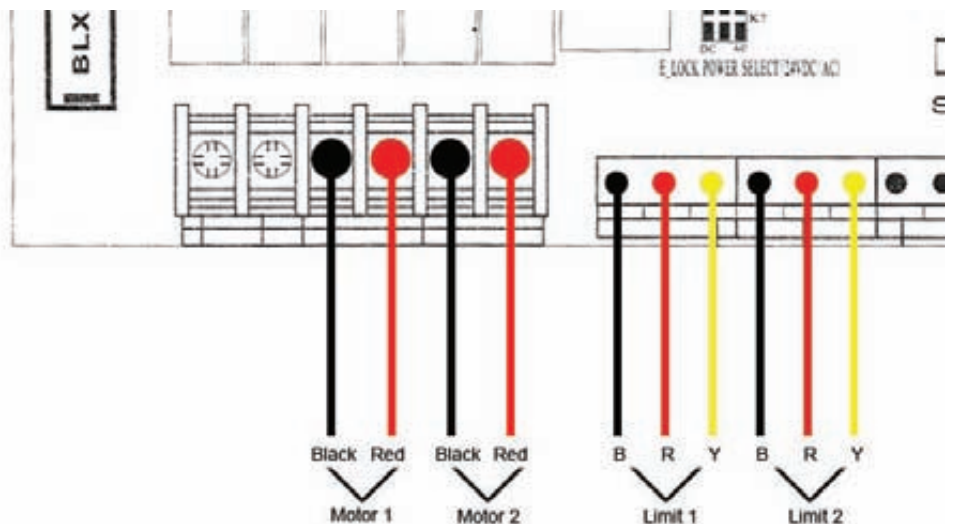

Installing and Setting Transmitters and Receivers

Receiver: Plug the receiver into the control board with the dip switches of the receiver facing the inside of the control board.

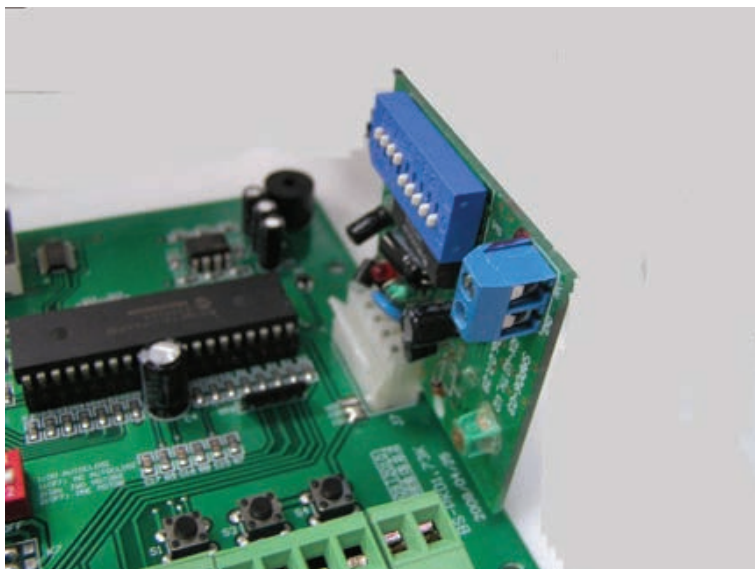

Dip Switches: There is no programming, simply match the 9 dip switch positions of the receiver to the 9 dip switch positions in the remote located under the battery lid.



Tip: If interference is occurring, change dip switches to another random position on both remote and receiver.



Temporary Safety Jumpers & Dip Switch Settings

If you are not using a safety device like a photo eye or safety loop the Photocell terminal must remain jumped to the GND terminal.

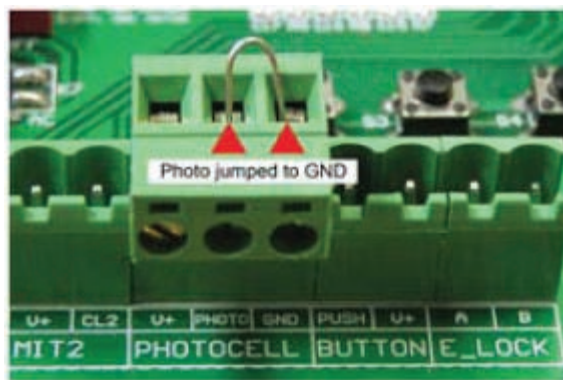

If you are using a SINGLE gate installation the LIMIT 2 terminals must remain jumped together.

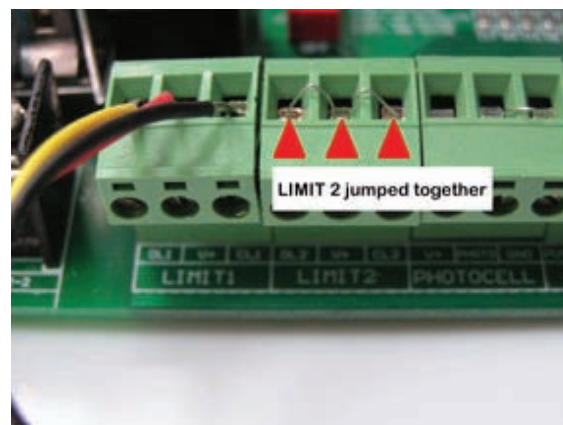

For a DUAL gate jumpers must be removed from limit terminals and limit switch wires inserted.

Dip Switches—To change either dip switch you must turn the power off before changing the setting.

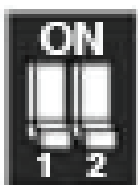

1. ON: Auto-close on (the gate will re-close from the open position after a time set in the programming section)
OFF: Auto-Close off
2. ON: Dual gate opener (2 motors)
OFF: Single gate opener (1 motor)



IMPORTANT: We recommend before turning the gate opener on for the first time to have dip switch 1 OFF. If the dip switch is set to on, the gate will autoreclose after turning it on without any intentional activation on your part.

Power

The Estate Swing E-S 300 comes with 1) 24V transformer. The transformer supplied has 2 screw terminals to connect to. You may locate the transformer up to 200' away from the control board using 16 gauge, 2 conductor stranded direct burial low voltage wire. Do not use solid core wire.

Insert the two wires from the transformer into the two TRAN terminals on the control board. The wires are not polarized, there is no positive or negative. Do **NOT SPLICE THE POWER CABLE WIRE**.



Never run 110VAC power directly to the Estate Swing.

This will destroy the Estate Swing control board.

Never connect the power wire with the transformer plugged in. Contact between the two lead wires, even for a second, will destroy the transformer.

Transformers are only warranted if the internal fuse is not blown. If the fuse is blown an outside factor (shorting, surge, water, etc) has caused the transformer not to function.

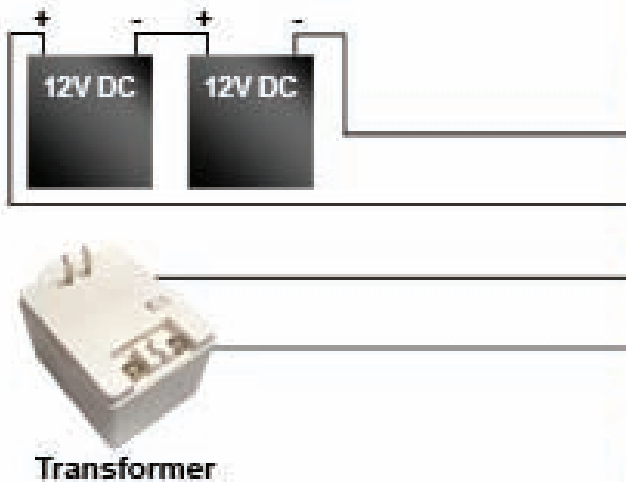

Plug the transformer into a 110 V AC outlet.

The transformer is not weather proof and must be kept in a covered area. Plug covers are available from your dealer, contact 1-800-640-GATE for a dealer in your area.

Two 12V DC batteries (Max 5 a/h per battery) may be run in series as backup to the 24V transformer power. Running two 12V batteries in series creates a 24V system, you cannot run them in parallel (see diagram above)

When you install new batteries - manually open the gate and allow the batteries to charge for 12 hours through the system before using the gate opener.

Find Limit Positions

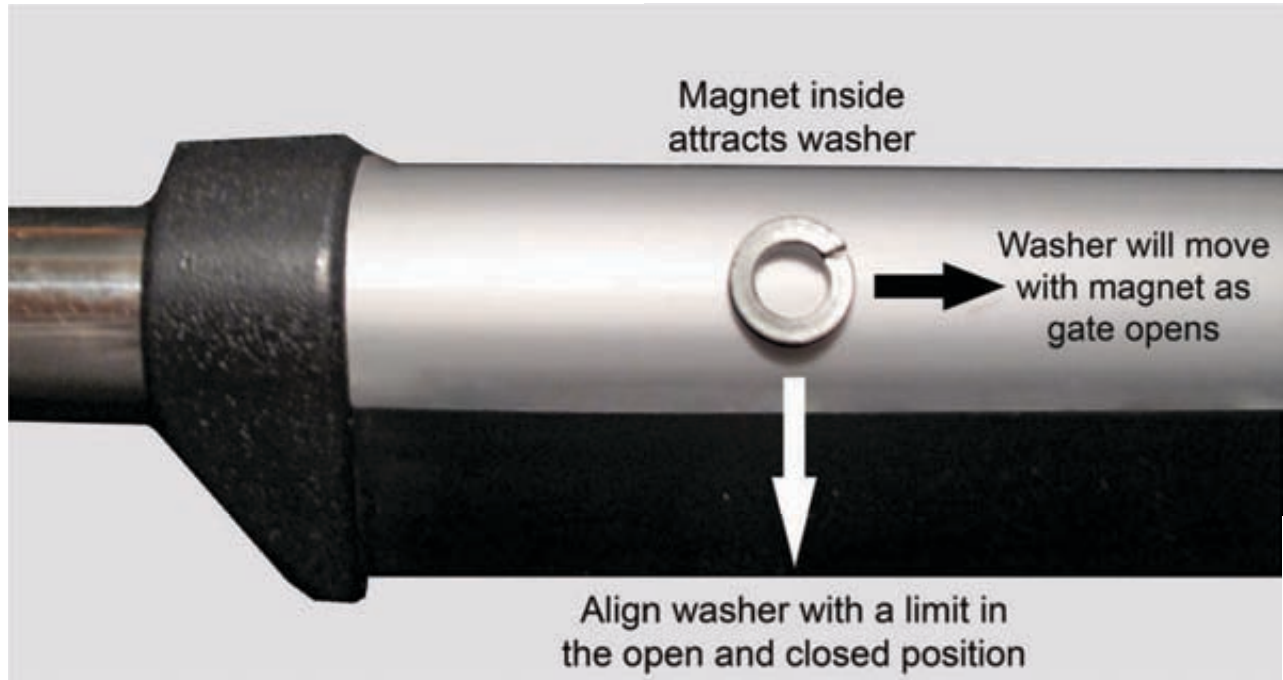

Example of washer and magnet in closed position (open for push-to-open)

1. Manually release the gate and move the gate to the desired closed position.
2. Take a metal washer and drag it along the side of the grey shaft until it is attracted by the internal magnet.
3. Move the limit switch on the bottom to line up with the washer.

Underneath the arm there are slides secured with Philip head screws. After loosening the screws the switches will be able to slide. (picture of limits on next page)

4. Move the gate to the open position and repeat with the open limit switch (as you open the gate you can leave the washer on the side and it will move along with the magnet).

Example of washer and magnet in open position (closed for push-to-open)



Determine Run Time

Once you set up your remote, press the button and actuate your gate a few times. When the gate stops on the limits: If the gate has stopped short of or further than desired position, adjust the limit switches:

After you have your limits in the correct position secure the position of the switches with the screws and run your gate through a few cycles. On the display you will see a count while the arms are moving. This is your run time. Record your run time below.

ACTUAL RUN TIME: _____



Operating Parameters Set Up

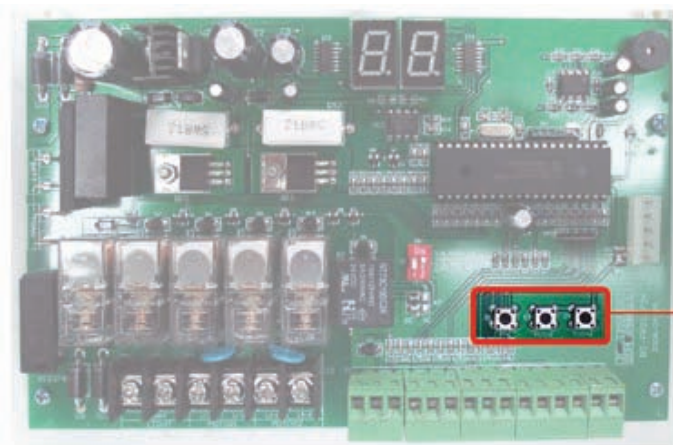

The SET, OPEN, CLOSE Buttons are located here

PUSH 1 or PUSH 2 to increase or decrease the parameter. Then press SET button to move to the next parameter.

1. Press SET button to begin.

2. LED shows P1: **P1 is for setting your run time.** The run time will be determined from the time you had determined during the set up of the limit switches. Take that determined run time and add 1 second. So if it takes 10 seconds to get from closed to open between limit switches; set the run time to 11 seconds. The options are 0-99 seconds.

3. LED shows P2: **P2 is for setting your slow down time.** The gate opener will slow down to half speed after the time set on P2 expires. If you wish to have the gate open and close faster make the slow down start time a longer period of time. If you want to put less stress on the gears and gate set the slow time shorter to slow the momentum sooner. The options will adjust to match the previously set run time. NOTE: *motor must be in slow down to detect limits—be sure this number does not exceed the time the motor take to move from one limit to the other.*

4. LED shows P3: **P3 is the force setting,** the lower the number the easier the gate will reverse directions when it meets resistance. This number may have to be changed to a higher setting if your gate is obstructing unexpectedly. The number should be set to the highest number during initial setup and reduced to the point of reliable operation that takes into account change in gate resistance through out the year. The options are 0-32.

5. LED shows P4: **P4 is for setting a delay between leafs** if you have overlapping gates or a gate lock. The motor wired into the master terminals (1) opens first if there is a delay and closes second. It is recommended to have a delay of 3 seconds to avoid any jamming issues between leafs.

6. LED shows P5: **P5 is the delay for automatic re-close** from the open position – this option needs to be turned on using the dip switch on the board. The options are 0-99 seconds.

7. LED shows P6: **P6 is the release for the gate lock** – this option determines the length of time 24VDC will be sent out of terminals E_LOCK. *The options are 1-4 seconds.*

8. Press SET to finish. You should hear 3 beeps; this indicates parameter programming is finished.

Troubleshooting

If the gate opener will not move: (also see "one or both arms are not moving" on next page)

- Check wiring connections.
- Check to be sure safety jumpers are in place .
- If not using slave limit switches, be sure jumpers are in place.
- Be sure the arms are locked and not in manual operation.
- Check the fuse near the power supply—the proper way to inspect a fuse is to remove it from its clips and check for continuity.

If the gate opener move a few inches or feet and stops or reverses directions:

- Increase the force setting.
- Check the setback. The setback of the operator is important to correct operation due to leverage the arm will have on the gate.

The gate does not reach the desired stop points:

- Adjust the limit switches.
- Lengthen the run time parameter.
- Check setback— if setback is incorrect it will limit how far the gate will move per inch of stroke length.

If the gate will open but will not close:

- If you are **not** using safety devices the safety jumpers are in place.
- If you are using a safety device:
 - Check to make sure you are using the normally closed connection instead of the normally open.
 - Check to be sure there is continuity being provided between the common and normally closed wire of the safety device. If there is not continuity then refer to the installation guide of the device to set up properly.

The display of the board will not light up:

- Check the power supply for 24VAC.
- Check the fuse near the power supply—the proper way to inspect a fuse is to remove it from its clips and check for continuity.
- The arms are not wired in or properly wired on the limit switch connections. With out the limit switch connections being closed the board will not light up.

If limit motor is opening or closing past the limits

- Motor must be in slow down mode to detect limits. Check P2 parameter. The slow down occurs AFTER the number that parameter is set to expires. *Example: If P2 is set to 14 and it takes 13 seconds to move from closed to open it will not enter slow down mode. Decrease this number.*

More on next page

Troubleshooting

The gate opener is not stopping on the limit switches:

- Remove all pre-installed jumpers from the limit switch terminals that have limits going to them. The slave gate terminals come pre-jumped for single operation, if you are using a dual system pay particular attention to this detail and remove the jumpers when you put your limit switches in.
- The limits are wired incorrectly—be sure that you are following the correct wiring diagram for pull to open or push to open.
- Check setback—if setback is incorrect it will limit how far the gate will move per inch of stroke length.

One or both arms are not moving:

- Check to be sure wiring color pattern matches the installation (Example: push to open wiring for a push to open installation) - If the limits or motor are wiring opposite the installation the board will believe it is closed or open when it is actually the opposite and the arms will never move.
- Check the limit wires are correctly in the terminal blocks. The terminal blocks come with the terminal clamps closed - however when the terminal clamps are closed there is a small space below them one could mistake as place to insert a wire. If this is done then conductivity of the connection will never be reached.
- Push or pull on the gate - if it moves the gears are disengaged and the gate is in manual release mode.

General fix for user to understand operation.

Unlock the gate opener arm and move it to the half way position. Change the run time to a low number (example: 2). Run the operator repeatedly.

The operator should run one direction for a 2 count and then the other for a 2 count. After you feel you have it following the run time correctly and swinging level and easily, then start incrementally lengthening the run time.

Eventually the run time will allow the operator arm to reach both limit switches and your setup is complete.

Single gate - Arm retracts and extends in a jerky manner:

The jumpers are not in place on LIMIT 2—all three need to be jumped together.

Dual gate - Only one arm moves:

- If one arm reaches a limit before the other arm moves, that other arm will never move. In other words, second arm must move before first hits limit.
- If the device you are using to activate the gate is wired into PUSH 2 that only opens leaf 1.
- Check your dual settings - if the dip switch is changed to dual with the power on the setting will not take effect, turn the power off and then back on to have the dual dip switch take effect. *NOTE: If one leaf of a dual gate ever reaches its end limit before the other leaf starts moving, the leaf that hasn't started moving will not begin: correct this by cycling the gates again and let it travel the full stroke or decrease the delay between leaves. The options are 0-9 seconds delay.*

Troubleshooting



IF YOU CALL IN FOR TECHNICAL SUPPORT OR WARRANTY SUPPORT: Before any control board or motor will be permitted to be sent in for testing or warranty you will be required to e-mail digital photos to the technician.

This is done in your best interest to save unnecessary shipping expenses and time lost. Many times we can come up with solutions to issues by seeing pictures that relay information that is impossible to relay through a phone conversation.

Below are examples of control board pictures and motor pictures that we will be looking for:

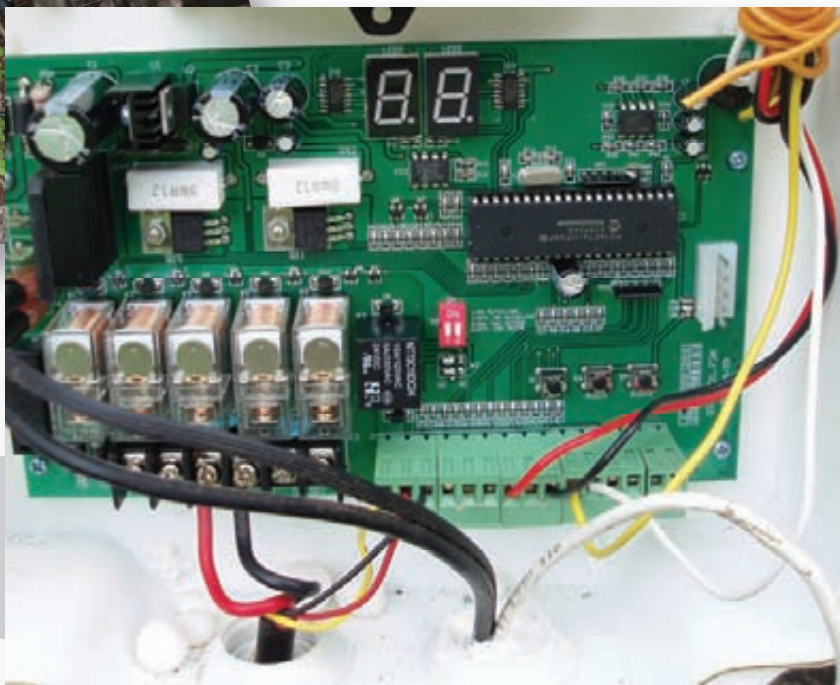

Pictures shown are actual customer photos

Control Board Overview



CAUTION! Do not run 110V AC power direct to the board. This will cause permanent damage to both boards and void your warranty. Caution!

Gate Opener reactions to signals:

PUSH1 and Receiver (PUSH 1 terminal, PUSH 1 button, 5 Prong Receiver):

Details:

- Will activate gate with momentary contact (momentary contact between PUSH1 and V+) or if you momentarily press the PUSH1 button.
- Controls both leaves in 2 leaf mode (Dip switch 2 in the ON position).
- Acts as party mode control to suspend auto-reclose by activating while counting down autoreclose in the open position.

Operational Sequence for terminal with autoclose ON (Dip switch 1 in on position):

1. In closed position - momentary contact will open gates.
2. When opening - momentary contact will stop gates and then it will auto reclose.
3. When stopped mid cycle waiting auto reclose - momentary contact will move the gate in the direction opposite what it was moving before stopped.
4. When open and counting auto-reclose pause time - momentary contact will stop pause time.
5. Stopped in open position from override of auto-reclose from PUSH1 or Receiver - momentary contact will reactivate pause time and close gate.
6. When closing - momentary contact will stop the gate and then it will auto reclose.

Operational Sequence for terminal with autoclose OFF (Dip switch 1 in off position):

1. In closed position - momentary contact will open gates.
2. When opening - momentary contact will stop gates.
3. When stopped mid cycle - momentary contact will move the gate in the direction opposite what it was moving before stopped.
4. When open - momentary contact will close gates.
5. When closing - momentary contact will stop the gate.
6. When stopped mid cycle - momentary contact will open the gate.
7. When open with auto-reclose off - momentary contact will have no effect.
8. When closing - momentary contact will re-open the gate.

Control Board Overview



CAUTION! Do not run 110V AC power direct to the board. This will cause permanent damage to both boards and void your warranty. Caution!

Gate Opener reactions to signals:

PUSH2 (PUSH 2 terminal and PUSH 2 button):

Details:

- Will activate gate with momentary contact (momentary contact between PUSH2 and V+).
- Controls **both** leaves in 2 leaf mode (Dip switch 2 in the ON position)..
- **Only opens the gate, never closes it.**
- Pause time is able to be re-set indefinitely if this terminal is continuously closed through a non-momentary contact (a connection between PUSH2 and V+ that is not released) Then the time will be reset and held until the connection between PUSH2 and V+ is released - then it will count down the pause time and reclose.
- **Ideal for exit wand or exit loop.**

Operational Sequence for terminal with autoclose ON (Dip switch 1 in on position):

1. In closed position - momentary contact will open gates.
2. When opening - momentary contact will have no effect.
3. When stopped mid cycle from PUSH 1 or the Receiver - momentary contact will open the gate.
4. When open with auto-reclose on - momentary contact will re-set pause time and will start counting again after release of momentary contact. Closed contact will continually re-set pause time and start counting down to reclose again after contact is released.
5. When pause time countdown is stopped in open from a momentary contact of PUSH 1 or the Receiver - momentary contact will have no effect.
6. When closing - momentary contact will re-open the gate.

Operational Sequence for terminal with autoclose OFF (Dip switch 1 in off position):

1. In closed position - momentary contact will open gates.
2. When opening - momentary contact will have no effect.
3. When stopped mid cycle - momentary contact will open the gate.
4. When open with auto-reclose off - momentary contact will have no effect.
5. When closing - momentary contact will re-open the gate.

PUSH 1 and PUSH 2 – these terminals can hold as many normally open connections as needed, they will be wired in parallel. They are used for keypads, push buttons, universal receivers, etc.

Control Board Overview



CAUTION! Do not run 110V AC power direct to the board. This will cause permanent damage to both boards and void your warranty. Caution!

Lamp Terminal: Sends pulses of 24VDC during opening and closing – to be used with a 24VDC lamp.

Sends a pulse (length of time determined by P6 parameter) of 24VDC for a solenoid gate lock during opening.

E_Lock: A second 1 second pulse of power will be sent after the closed limit switch is reach to assist in relocking the gate lock.

Magnetic gate lock must be powered separately and this terminal can be used to activate a relay that cuts power to the magnetic lock at the beginning of a cycle.

**V+/
Photocell/
GND:** Provides 12V to be used with a photocell for gate safety. The photocell terminal is a Normally Closed connection – **it must be jumped to GND when not being used.**

The power output on this terminal is very minimal, do not exceed one accessory or 300 milliamps.

Do not attach accessories until after you have the gate opener limit switches and parameters set up and the gate opener functioning properly by remote.

Control Board Overview



CAUTION! Do not run 110V AC power direct to the board. This will cause permanent damage to both boards and void your warranty. Caution!

Display Indicators:

Lower right hand "dots" flashing normal pace:

Awaiting command / normal operation

Lower right hand "dots" flashing rapidly:

Safety terminal triggered / lacks connection

EL: Sending voltage to EL terminals (electric lock)

OP: Opening cycle

AU: Auto-reclose countdown

CL: Closing cycle

If the gate(s) come in contact with an obstruction the gate(s) will reverse direction for 2 seconds and stop to allow the obstacle to be cleared from the gate path.

Buzzer/ Obstructions:

If the gate(s) obstructs 3 times in a row the gate(s) will go into a hard shutdown mode and a buzzer alarm will sound. At this point no accessories or remotes will be able to activate the gate opener until the gate opener is reset by disconnecting primary power (transformer) and secondary power (back up batteries - if applicable).

Installing Accessories

Accessory manuals for most make and model accessories can be found on the web at:

www.EstateSwing.com/accessories

The accessory manuals you have or find at the above address may be written to coincide with that manufacturer's model of gate opener. To determine correct terminals on your Estate Swing operator, use the accessory terminal section of your Estate Swing manual. The following are some common terms and abbreviations found in manuals:

Normally Open – abbr. N/O – Indicates a circuit that is left open during normal operation of the gate operator. When a device closes this circuit it signals the operator to perform a function. This circuit is the main circuit for entry devices. (i.e. keypads, exit wands, push buttons, etc.)

Normally Closed – abbr. N/C – Indicates that in order for the gate opener to be active this circuit must be closed. When a device opens this circuit it stops the motion of the gate operator. This circuit is the main circuit for safety devices. (i.e. photo eyes, safety loops, etc.)

Common – abbr. COM – This is the matching terminal for both Normally Open and Normally Closed circuits to be connected to. Accessory wiring that begins in a N/O or N/C terminal must have a wire that ends in a Common terminal.

Ground – abbr. GND or GRD – Ground is sometimes also known as negative. Common terminals are the same as Ground terminals. Ground can also be the negative spade of the battery if it is being used in association with positive voltage.

If a device has both a N/O and a N/C wire, both are never used at the same time. Some devices can be used as either an opening device or a safety device (i.e. gate crafters exit wand, NIR photo eye, etc.) If being used as an opening device use the N/O and if being used as a safety device use the N/C terminals.